

SVOJINA FKL-a TEMERIN. Bez pismenog odobrenja crtez ne sme biti korišćen za izradu niti davan trećem licu ili reprodukovano. FKL zadržava sva prava koja mu po Zakonu pripadaju. PROPERTY OF FKL TEMERIN. This drawing must not be used for manufacture not given to other parties or reproduced without written permission FKL reserve all rights belonging.

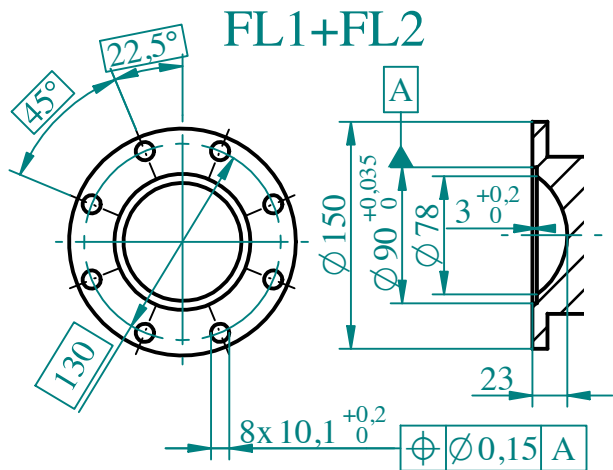

FKL TO VERIFY

COMPANY:

DATE: SIGNATURE:

19.05.2011

-Max. Torque	8000 Nm
-Max.deflection angle	30°
-Max. length compensation	110 mm
-Max speed n=	300 rpm
-Lubricant	LICAL EP-2
-Painting	Red IC-105

R.br	ID:	NAZIV	OZNAKA	Kom
1	771885	FLANGE YOKE	150.P1-8x10	2
2	730031	UNIV. JOINT	150.B1.00-48x121.8	2
3	771884	TUBE YOKE	150.G1	1
4	775405	TUBE	PC-85.5-598	1
5	771883	SPLINED SLEEVE	150.C35	1
6	182646	GREASE NIPPLE	AM10X1	1
7	773972	GASKET	70X80-150	1
8	771886	COVER TUBE	ZC-150-140	1
9	771885	SHAFT YOKE	150.V1	1

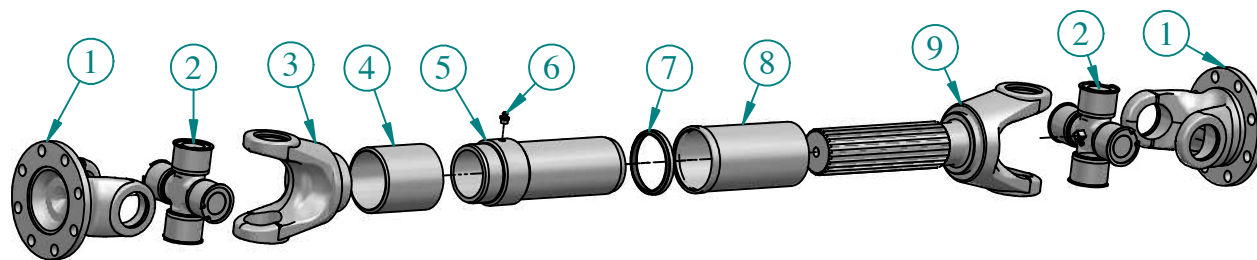

FKL		Tolerancija slob.mera	Hemijsko-termička obrada:	
Konstruisao	Datum	Ime	Materijal:	Masa: 30.9 kg
Pregledao	17.05.2011	KomanL	Veza: FKL-Russia-002/0609 - poz 1.2	Razm:
Overio	19.05.2011	Marčetić D. Mijušković M.		
Ident:	Naziv:	Oznaka:		
703244	CARDAN SHAFT	B150.01.1125.P1-8X10		

Sifra Datum Opis
IZMENE
290505