

# DETAIL A

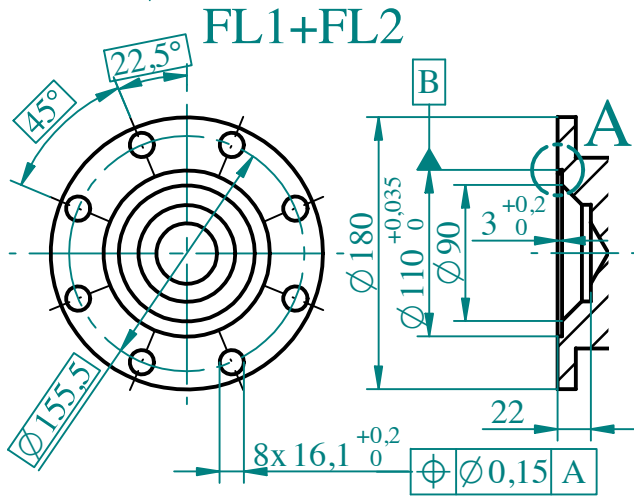
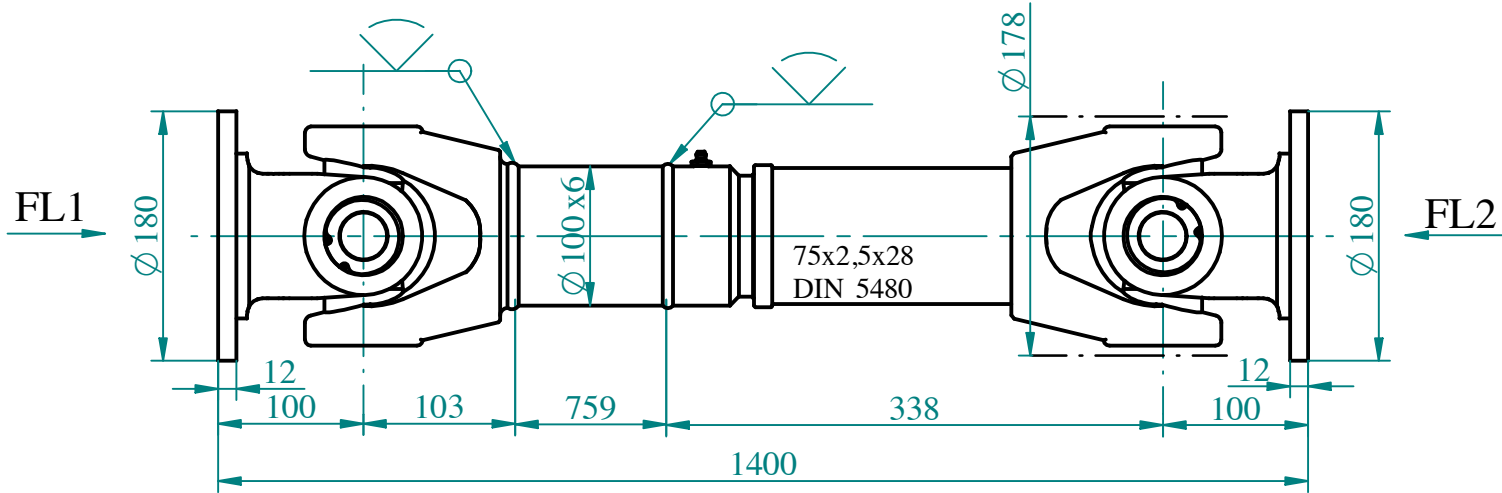
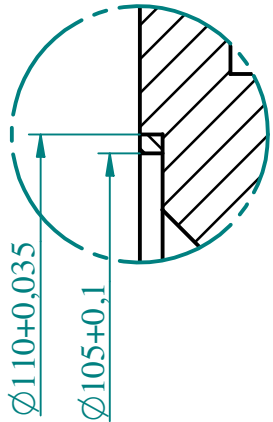

**FKL** TO VERIFY

COMPANY:

DATE: SIGNATURE:

19.04.2013

SVOJINA FKL-a TEMERIN. Bez pismenog odobrenja crtez ne sme biti korišćen za izradu niti davan trećem licu ili reprodukovano. FKL zadržava sva prava koja mu po Zakonu pripadaju.  
 PROPERTY OF FKL TEMERIN. This drawing must not be used for manufacture not given to other parties or reproduced without written permission FKL reserve all rights belonging.

-Max. Torque	12000 Nm		
-Max.deflection angle	30°		
-Max. length compensation	140 mm		
-Balancing	ISO 1940/1-G16		
-Max. speed	n= 200 rpm		
-Lubricant	LICAL EP-2		
-Painting	Red IC-105		
R.br	NAZIV:	DIM:	Kom
1	Flange Yoke	180 / 8x16	1
2	Universal Joint	Ø57x144	2
3	Tube Yoke	Ly=100X6	1
4	Tube	Ø100 Lt=759mm	1
5	Splined assy	75x2.5x28 DIN 5480	1

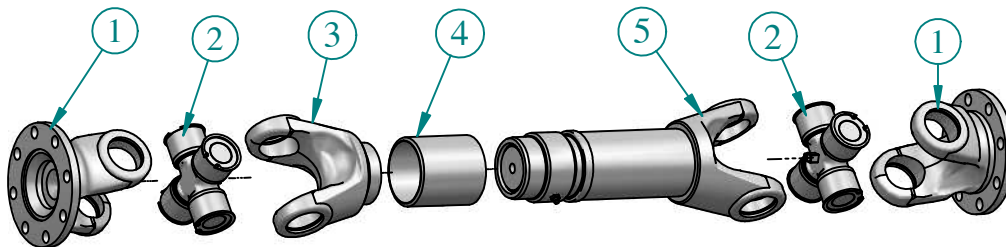

<b>FKL</b>		Tolerancija slob. mera	Hemijsko-termička obrada:	
Konstruisao	Datum	Ime	Materijal:	Masa:
Pregledao	19.04.2013	KomanL		56 kg
Overio	19.04.2013	Marčetić D.	Veza: FKL - Russia	Razm:
	19.04.2013	Mijušković M.		
Ident:	Naziv:	Oznaka:		
703466	CARDAN SHAFT KARDANSKO VRATILO	B180.01.1400.P1.105		

Sifra Datum Porisak  
 IZMENE  
 290505